

CUSTOMER'S NAME:	
CUSTOMER'S P.O. NO.:	
REOTEMP ORDER NO.:	
CERTIFIED BY:	DATE:

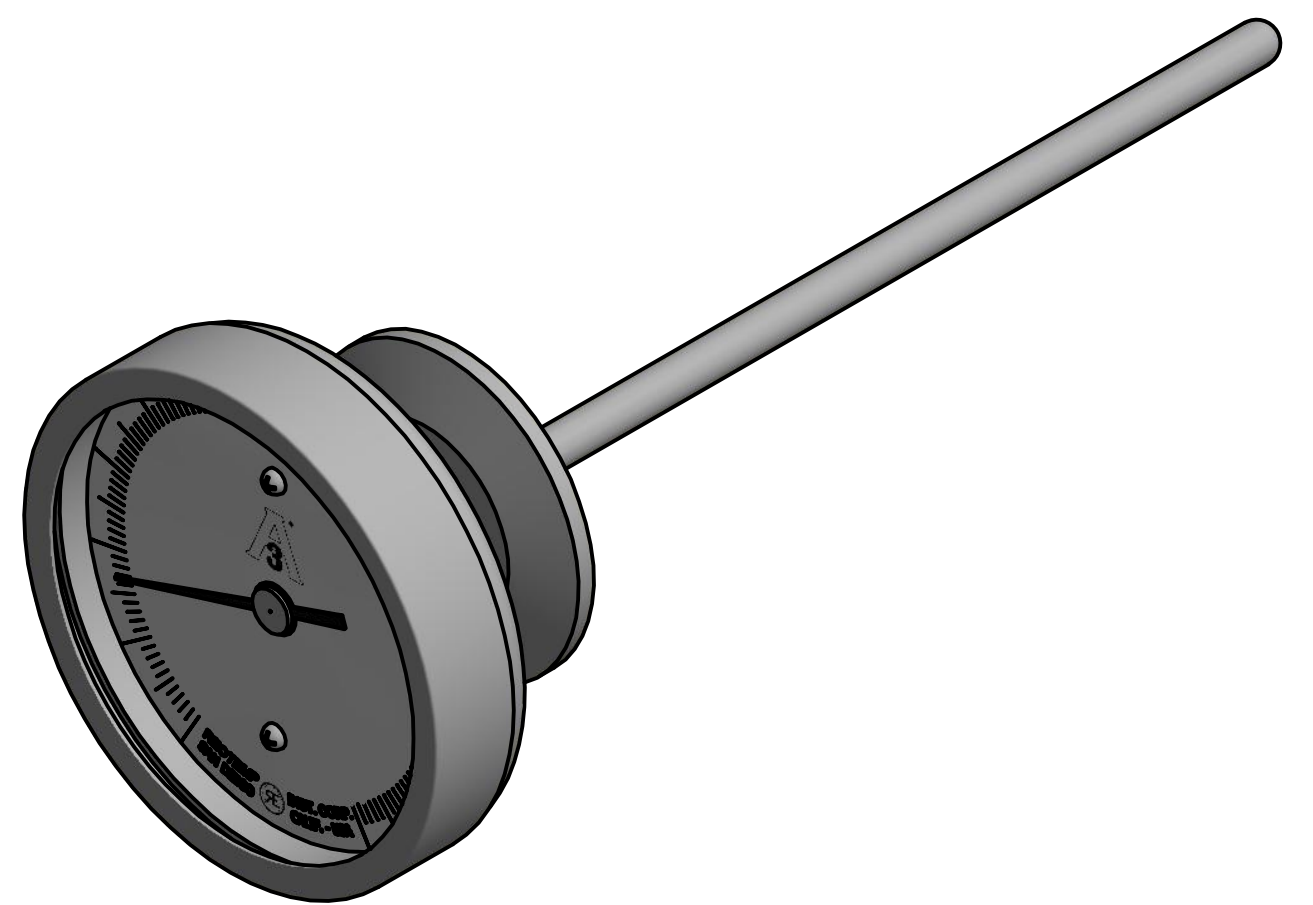
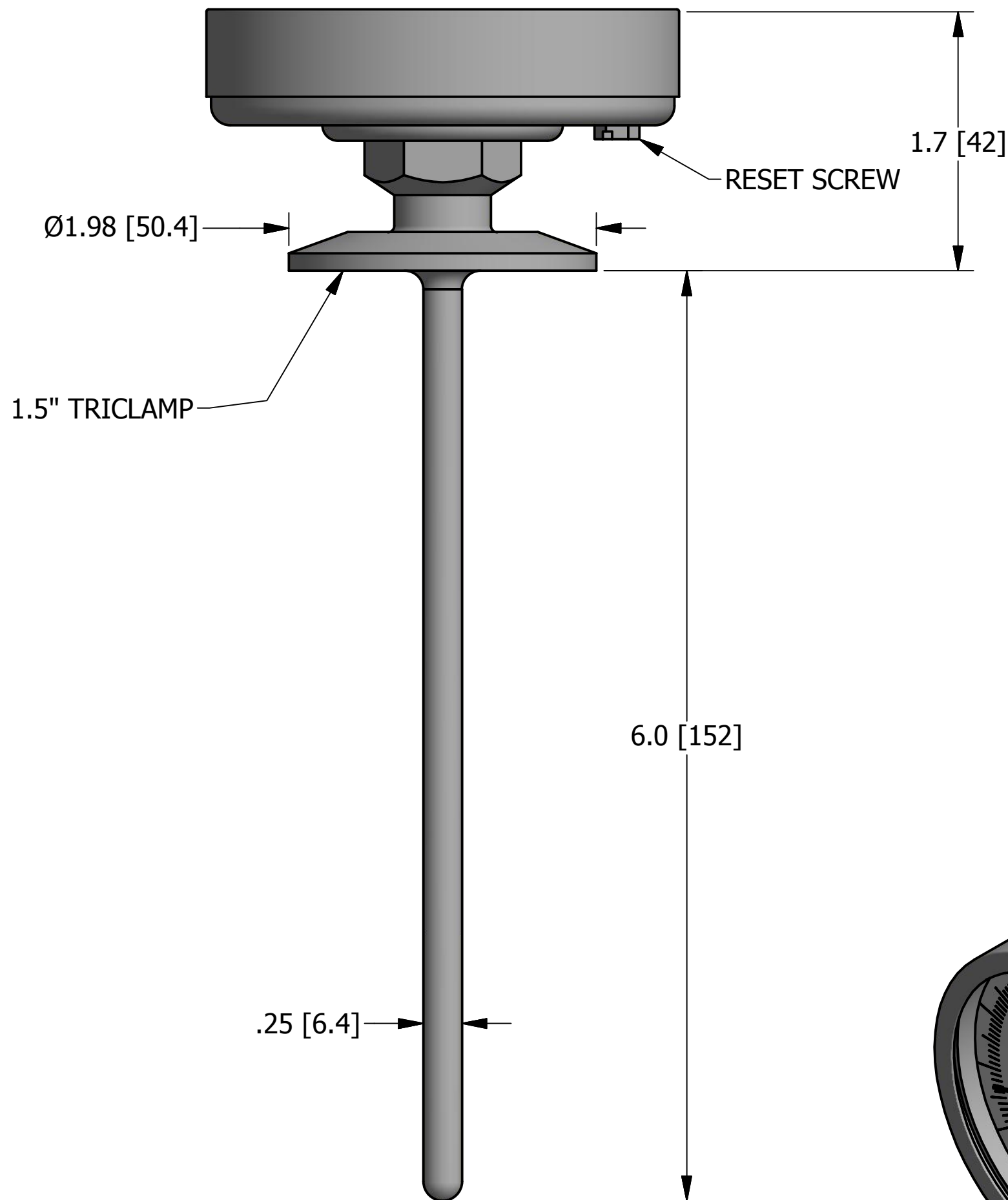
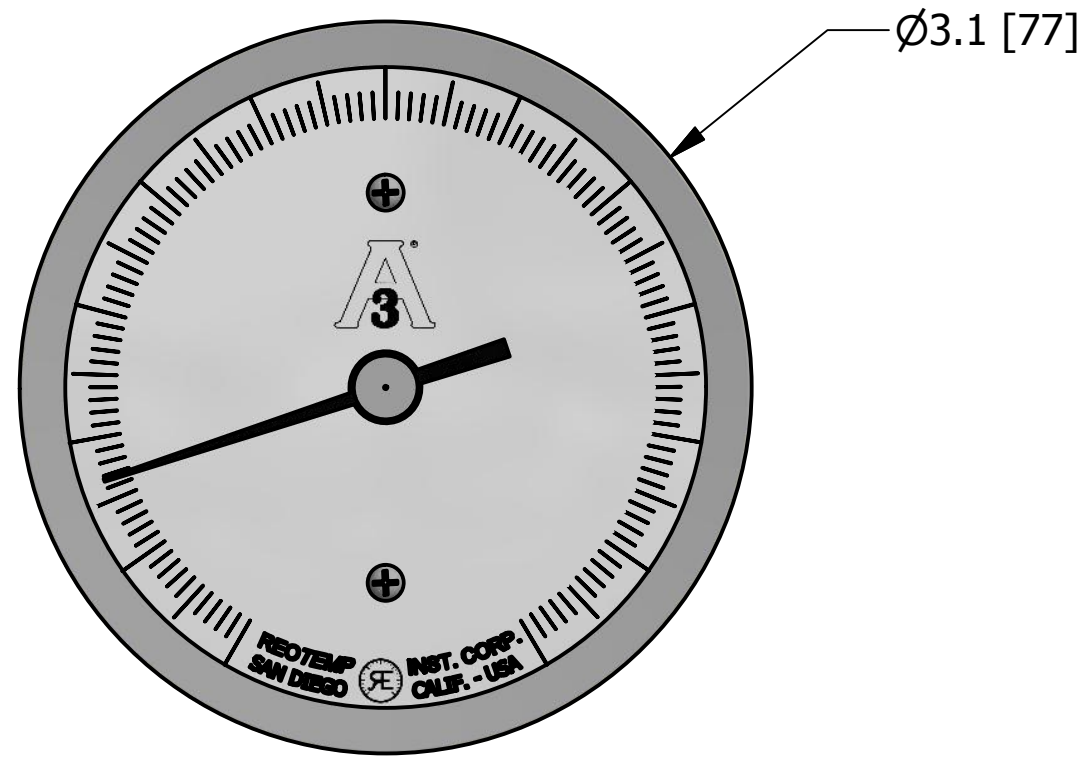

REVISIONS

REV	DESCRIPTION	DATE	APPROVED
A	INITIAL RELEASE	9/2/15	

WETTED MATERIAL: 316/316L STAINLESS STEEL		UNLESS OTHERWISE SPECIFIED DIMENSIONS ARE IN INCHES & [mm] TOLERANCES ARE:		PART NAME:		DATE:	
NOTE 2		FRACTIONS DECIMALS ANGLES ±1/32 .X ± .2 ±5°		3" BACK CONNECT W/ RESET, 1.5" TRICLAMP, Ø1/4" x 6" STEM		9/2/15	
NOTE 3		SURFACE FINISH 63√				DRAWN BY: MNeill	
NOTE 4		PART NO: AA060C		SIZE: C	CAGE CODE: 24793	APPROVED:	
NOTE 5		FIRST USED ON:		SCALE: NTS		REV: A	
				FILE NAME:		SHEET 1 OF 1	