

Lead Wire Configuration

Plain Leadwires (Most are supplied without a transition)

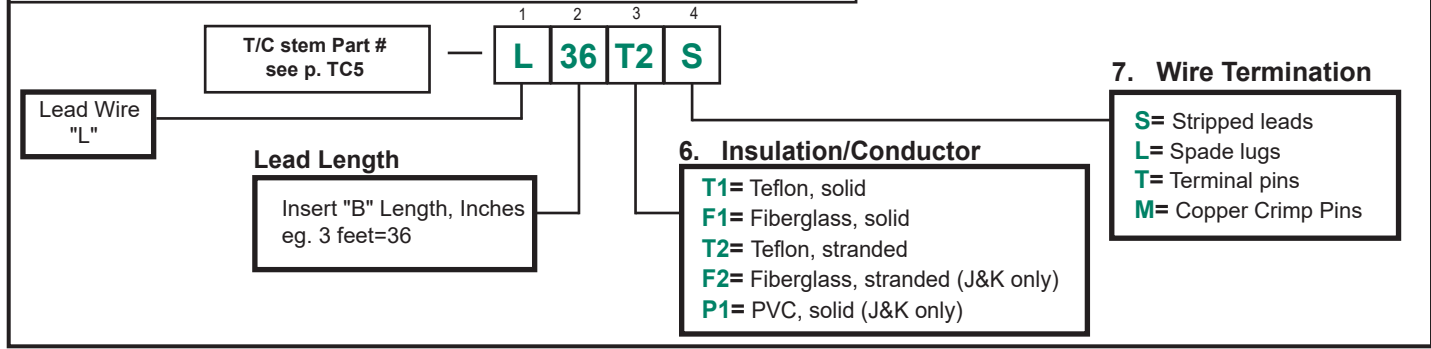

Other Leadwires (These require a transition)

Transitions - Table (A)

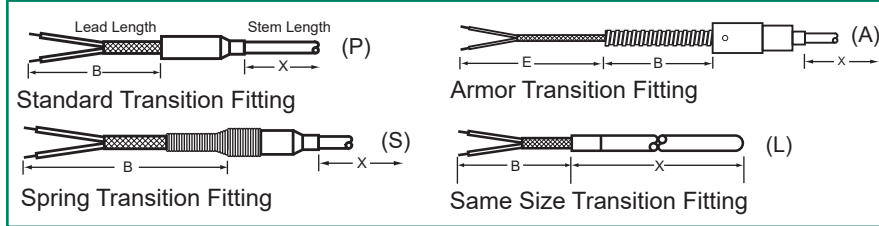

Terminations - Table (B)

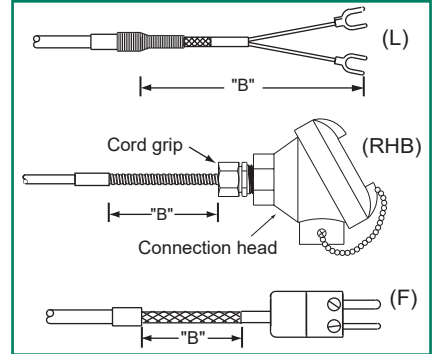

Example: APX125116X - **L6LJ2P36F1F**

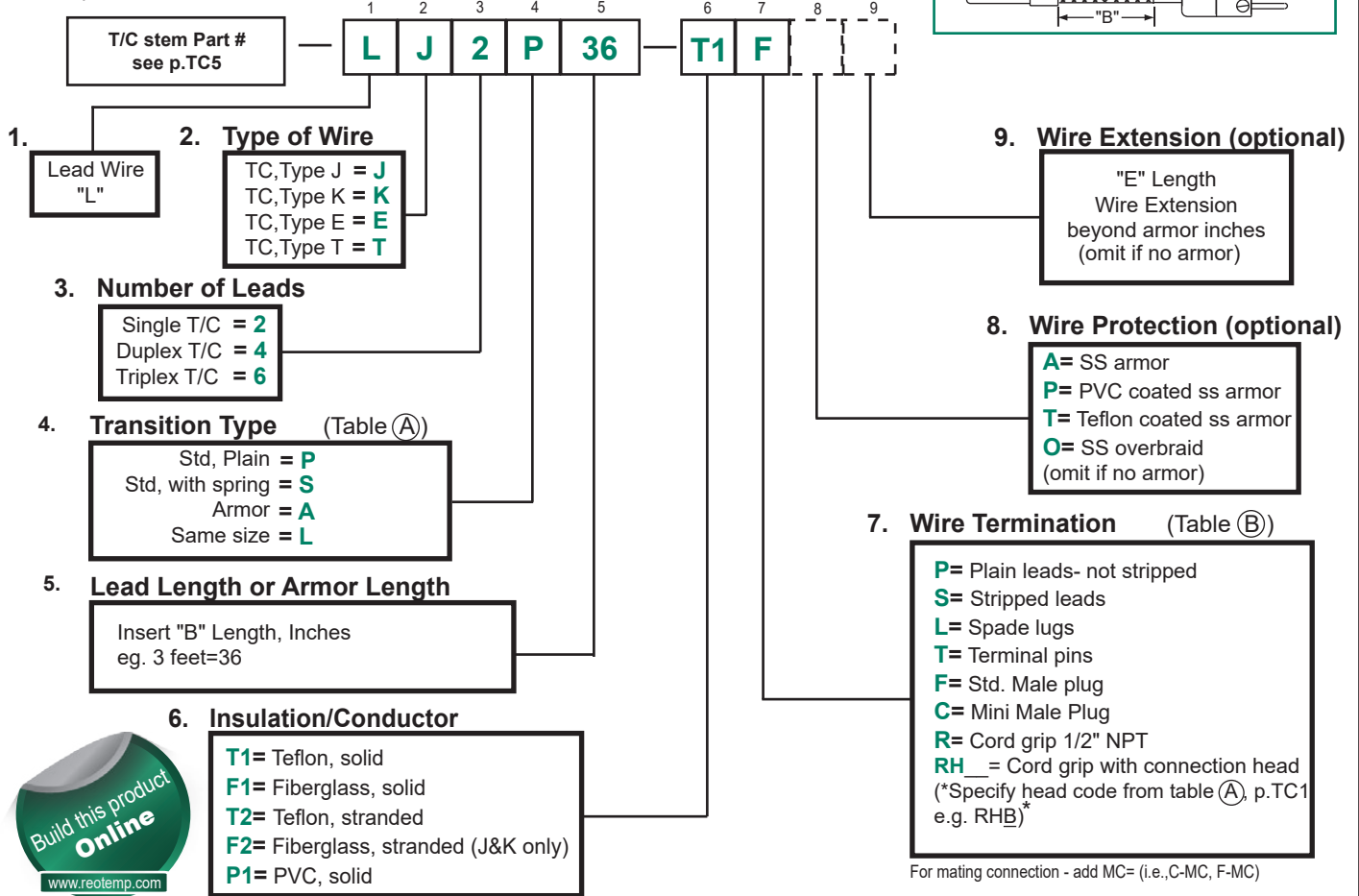

For mating connection - add MC= (i.e., C-MC, F-MC)