

## FLAMEBLOCK™

Reotemp's FlameBlock™ sensor improves safety by eliminating a flame path out of the head, while maintaining a spring loaded stem for positive thermowell contact. Containment of ignition is the standard method of protection with explosion proof assemblies. However, spring loaded stem assemblies universally have a pathway that could allow an ignition to escape the head and ignite ambient flammable materials.

With a welded CSA certified design, Reotemp's FlameBlock™ Sensor eliminates the flamepath out of the stem assembly - thus eliminating the escape of any ignition which could occur in the head - yet still provides the benefits of having a spring loaded connection. This unique design has found many applications where explosion proof assemblies are required.



### FEATURES / BENEFITS

- CSA Certified
- Spring Loaded Sensor without Direct Flame Path from the Head
- RTD or Thermocouple
- Class I, Div. 1, Gr A, B, C, & D

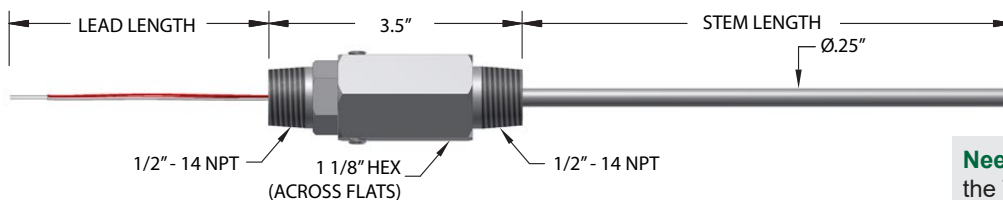
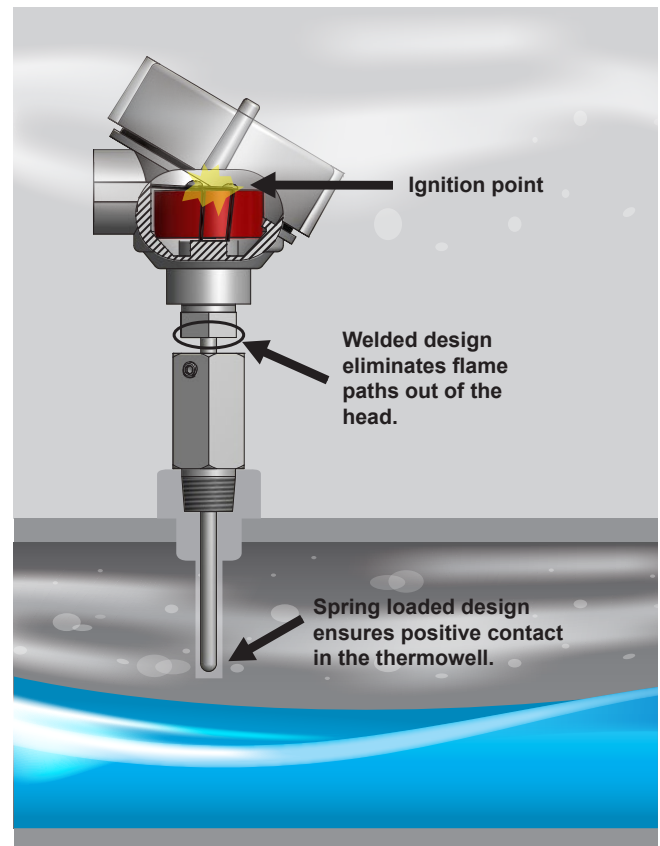

**Need Part Numbers?** Reference the Thermocouple and RTD Catalog. Look in the head assembly section and choose "8C" for process connection.