

CUSTOMER'S NAME:	
CUSTOMER'S P.O. NO.:	
REOTEMP ORDER NO.:	
CERTIFIED BY:	DATE:

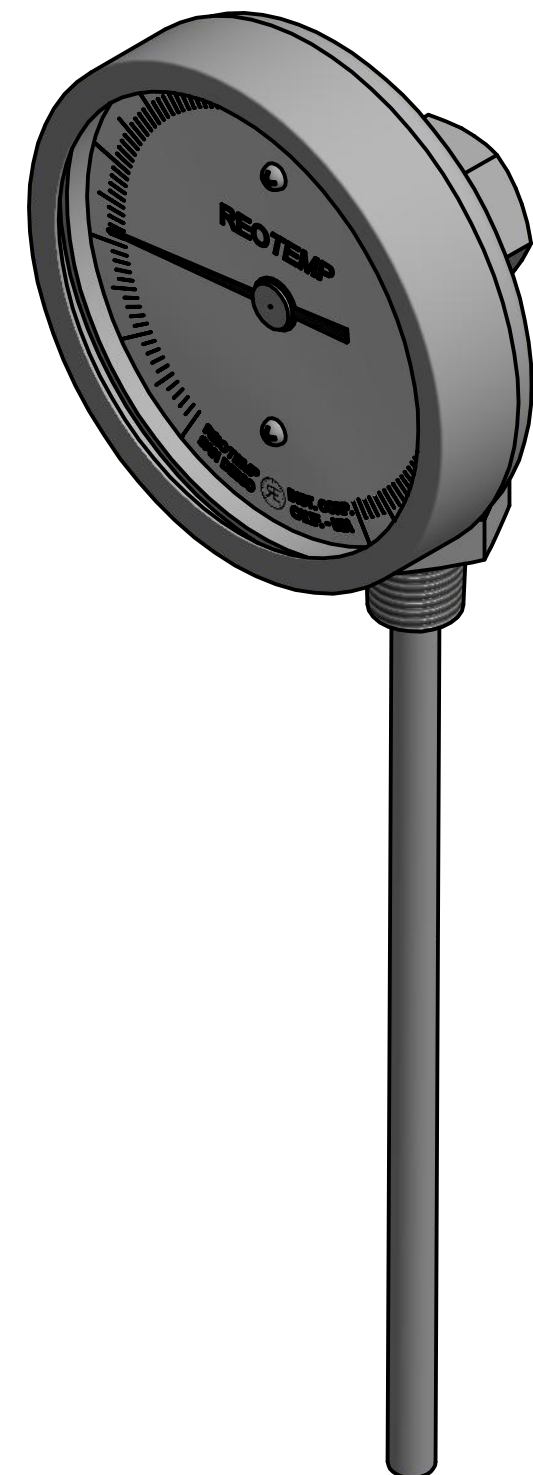
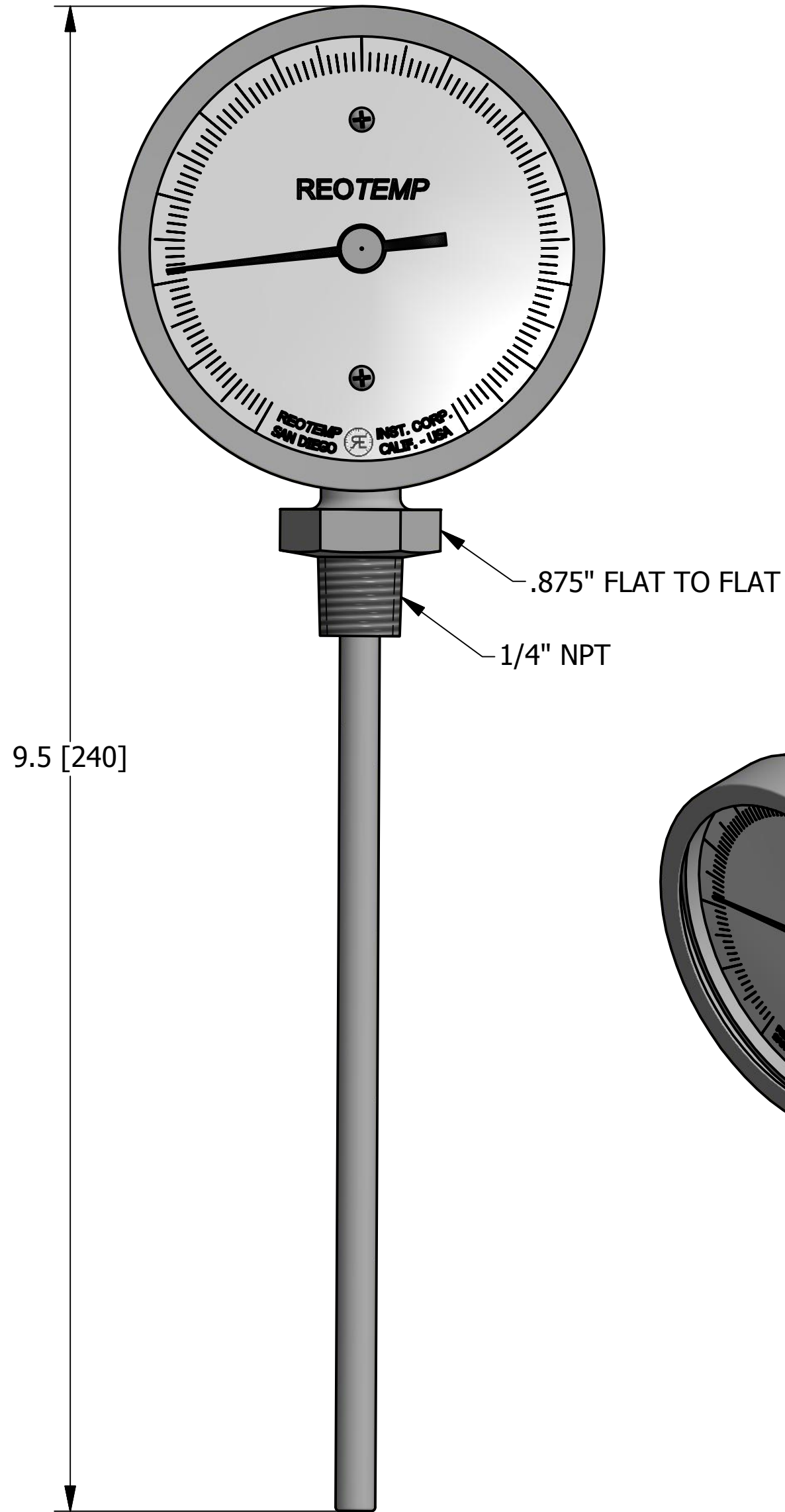
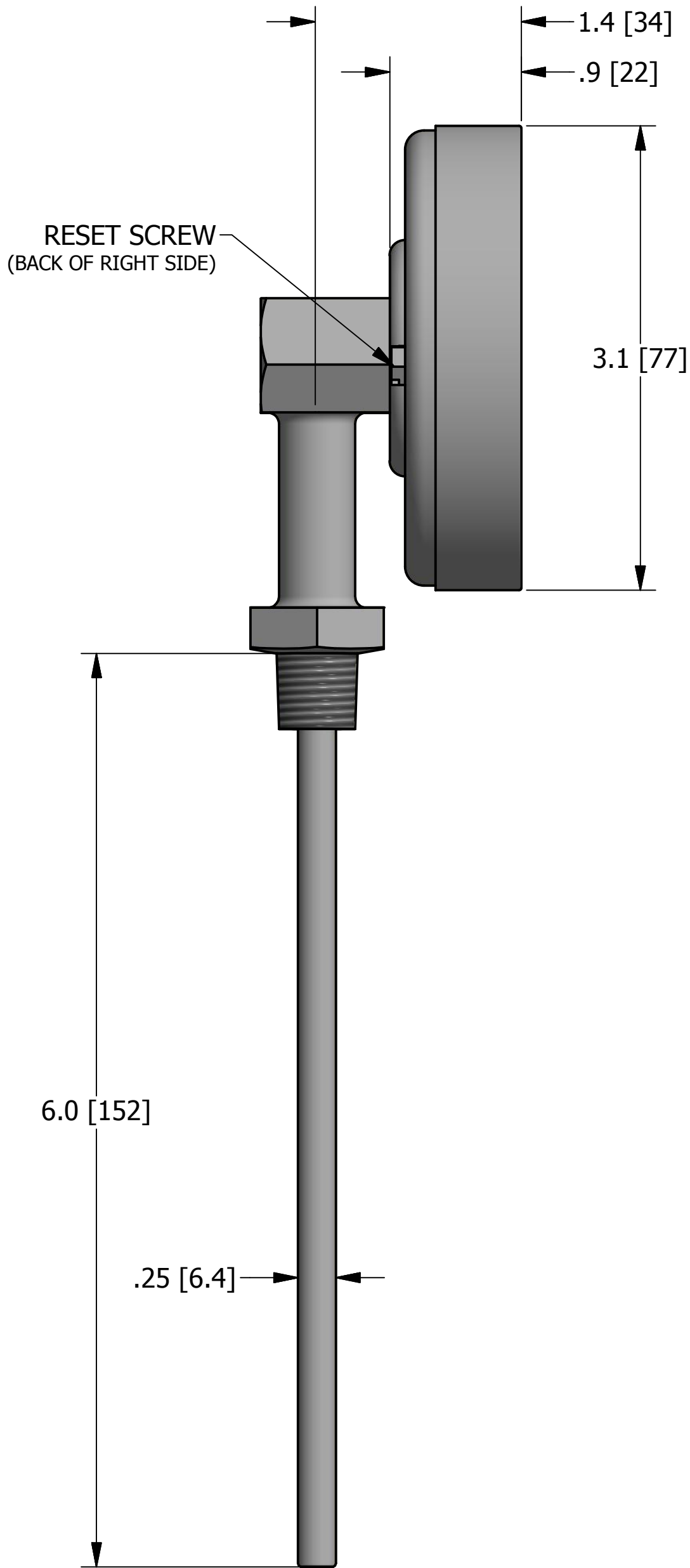

REVISIONS			
REV	DESCRIPTION	DATE	APPROVED
A	INITIAL RELEASE	8/28/15	

NOTE 1	UNLESS OTHERWISE SPECIFIED DIMENSIONS ARE IN INCHES & [mm] TOLERANCES ARE: FRACTIONS DECIMALS ANGLES ±1/32 .X ± .2 ±5' .XX ± .01 .XXX ± .005 SURFACE FINISH 63√	PART NAME: 3" BOTTOM CONNECT W/ RESET, 1/4" NPT, Ø1/4" x 6" STEM		DATE: 8/28/15
NOTE 2				DRAWN BY: MNeill
NOTE 3				APPROVED:
NOTE 4	PART NO: XR0604	SIZE: C	CAGE CODE: 24793	DWG NO:
NOTE 5	FIRST USED ON:	SCALE: NTS	FILE NAME:	REV: A
				SHEET 1 OF 1