

THIS DRAWING AND SPECIFICATIONS ARE THE PROPERTY OF REOTEMP INSTRUMENT CORP., AND ARE ISSUED IN STRICT CONFIDENCE AND SHALL NOT BE REPRODUCED, COPIED OR USED AS THE BASIS FOR MANUFACTURE OR SALE OF ITEMS DEPICTED HEREIN WITHOUT WRITTEN PERMISSION FROM REOTEMP INSTRUMENT CORP.

NOTES (UNLESS OTHERWISE SPECIFIED)

- 1) DIMENSIONS ARE IN INCHES
- 2) PRODUCTS TO BE BUILT PER REOTEMP CATALOG SPECIFICATION, UNLESS OTHERWISE SPECIFIED.

MSXPTAM2XP__HHMDDDC2XST-HV

MSXPT -- 4.5" Seal-Gauge, Black Phenolic Case, Solid Front-Blowout Back

A -- Bottom Mount

M2 -- 1/2" Male NPT Process Connection

X -- No Flush Port

P?? -- Pressure Range: Variable, Specified Below

HH -- Wetted Materials: Hastelloy C-276 Upper, Lower, and Diaphragm

M -- Pressure Gauge Materials: Monel Tube and Socket

DDD -- Seal-Gauge Connection: Direct Mount

C2 -- Seal Fill Fluid: Halocarbon 6.3

X -- Pulsation Dampening: None

S -- Case Fill: Silicone

T -- Lens: Tempered Safety Glass

HV -- Hi-Vis Dial, Dial Artwork pending Customer Approval

REVISIONS			
REV	DESCRIPTION	DATE	APPROVED
X1	INITIAL RELEASE	11/19/18	RY
X2	ADDED DIAL DETAIL, UPDATED PART#	1/23/19	RY

RANGE CODE (P??)	PRESSURE RANGE
03	-30inHg to 0 to 30psi
08	-30inHg to 0 to 300psi
17	0-60psi
20	0-200psi
21	0-300psi
22	0-400psi
23	0-600psi

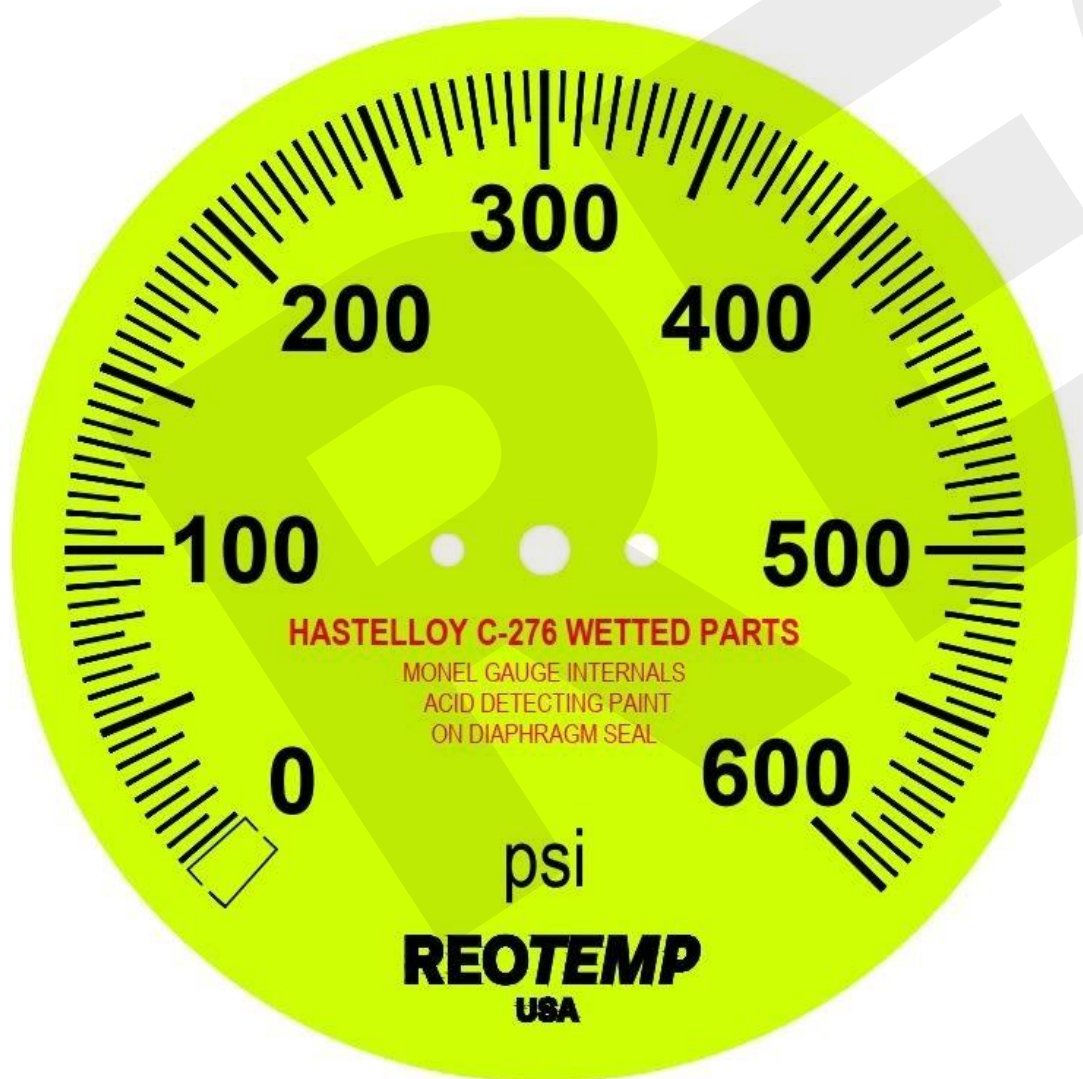
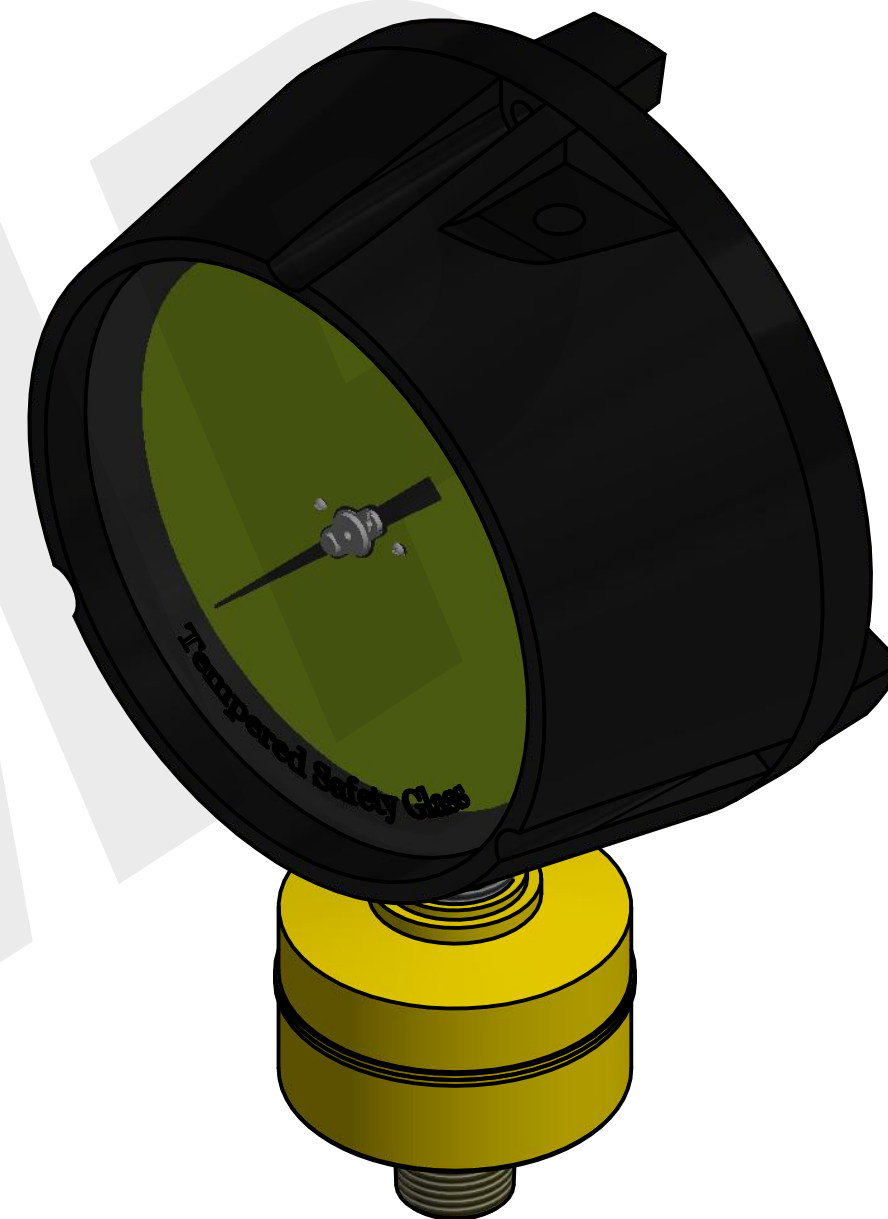
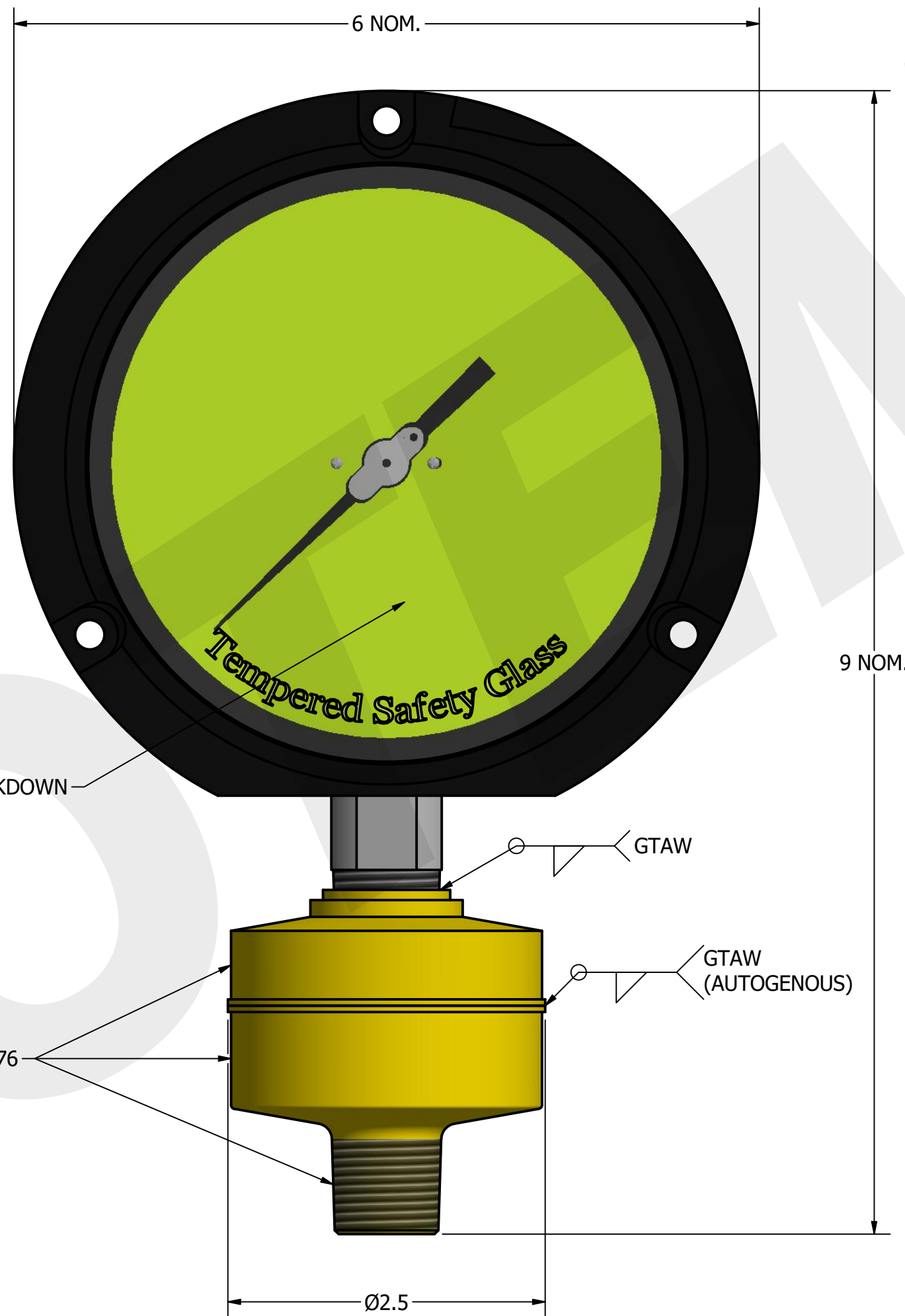

PART NAME All-Welded HF Acid Assembly, Threaded, Hastelloy Wetted, Monel Internals			
UNLESS OTHERWISE SPECIFIED DIMENSIONS ARE IN INCHES TOLERANCES ARE:		Reotemp Instrument Corporation 10656 Roselle Street San Diego, CA 92121 USA Phone: (858) 784-0710 Fax: (858) 784-0720	
FRACTIONS ±1/32	DECIMALS .X ± .03 .XX ± .01 .XXX ± .005	ANGLES ±1'	DATE 11/19/2018 DRAWN BY MNeill APPROVED BO
PART NO SEE PN BREAKDOWN	SIZE C	CAGE CODE 24793	DWG NO 20450 REV X2
FIRST USED ON	SCALE: NTS	FILE NAME:	SHEET 1 OF 1