

ReoCube Thermal Isolation Bottle Installation & Operation Instructions

REOTEMP

751-0222

GENERAL INFORMATION

Thermal Isolation counters rapid temperature fluctuations typically caused by doors opening in a walk-in freezer or cooler. The Thermal Isolation Bottle comes with all the items needed to add a buffer to any new or existing sensor installation. All the parts include the food grade Glycol or Glass beads buffer, 304 series stainless steel Mounting bracket, stainless steel screws, Nalgene Bottle, and probe fitting. The 2.0 oz Thermal Isolation bottle includes a PG7 Cable Gland with Neoprene Gasket (Seal) that will fit 3/16" to 1/4" probe sizes. The 8.5 Thermal Isolation bottle includes a 316 stainless steel well(s) with a compression fitting that will fit 3/16" diameter sensing probes only.

Glycol Isolation should be used in freezer/fridge applications, rated down to -40°C (-40°F). Glass Bead Buffer should be used in extreme low temperature applications, rated down to -100°C (-148°F).

The "3PT" Triple Point Thermal Isolation should be used in pharmaceutical or critical applications where multiple sensor redundancy is required with the 3rd sensing opening available for insertion of your NIST Certified standard or reference.

For optimal temperature measurement, follow these tips:

- The sensor should be installed inside the bottle such that the tip of the sensor is suspended approximately 1/2 inch above the bottom of the bottle. Make sure the tip is fully submerged in solution. Make certain the end of the probe where the wires exit, are kept above the liquid.

SENSOR INSTALLTION

Note: 2.0 (2oz) models are shipped with the original lid in place along with an additional lid drilled out with the sensor cord grip.

FIGURE 1: BOTTLE DIMENSIONS

2.0 oz Bottle

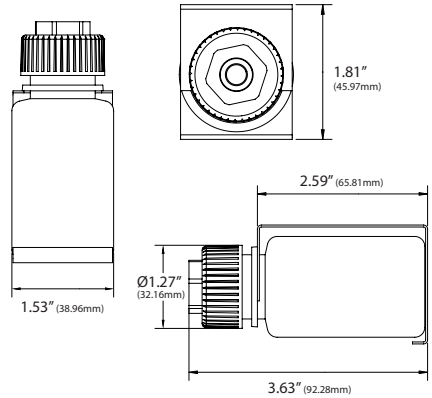

8.5 oz Bottle

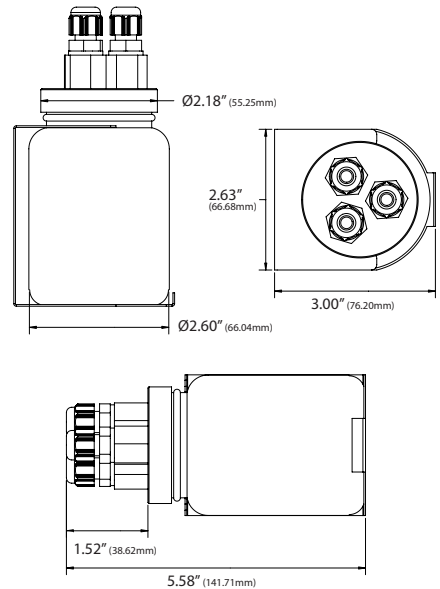

2 oz - GLYCOL

Insert the sensor probe into the water tight fitting. Insert from top of cap, and press down until the sensor is approximately ½ inch above the bottom of the bottle. Make sure the tip is fully submerged in solution. If the probe is tight, and not going in smoothly, unscrew the water tight fitting cap slightly.

While holding the probe against the nut, turn the cap clockwise to tighten to the probe. This will hold the depth position, so the probe does not slip.

Using the torque wrench with socket attachment, tighten the inner cap to 14.7 lb. inch (1.66 Nm).

2 oz - GLASS BEAD

Remove the compression nut and ferrule. Insert the sensor probe into the compression fitting body from top of cap, and press down until the sensor is approximately ½ inch above the bottom of the bottle. Insert the ferrule onto the probe first, followed by the compression nut. The ferrule is cone shaped, and can only be placed into the fitting body in one direction. The tip of the cone must be facing into the fitting body.

While holding the probe against the compression nut, turn the compression nut clockwise to tighten to the probe. This will hold the depth position, so the probe does not slip.

Hand tighten the compression nut first, followed by 1-2 turns with a pliers. Do not over tighten.

8.5 oz - GLYCOL OR GLASS BEAD

Insert the sensor probe into the water tight fitting/thermowell. Insert from top of cap, and press down until the sensor bottoms out. If the probe is tight, and not going in smoothly, unscrew the water tight fitting cap slightly. Turn the cap clockwise to tighten to the probe.

MOUNTING INSTRUCTIONS

Take care when mounting. The sensor should be mounted in an area where air circulation is well mixed and not blocked by obstructions. The Thermal Isolation comes with a stainless steel mounting bracket available for wall mounting.

MOUNTING BRACKET INSTALLATION

Drill pilot holes for the provided mounting screws. Use the mounting clip holes as a guide - see **FIGURE 2**. Drill the #10-16 1/2" screws through the bracket holes and fasten it to the wall. Insert the bottle into the bracket, and make sure it is seated securely.

FIGURE 2: STAINLESS STEEL MOUNTING BRACKET (Optional)

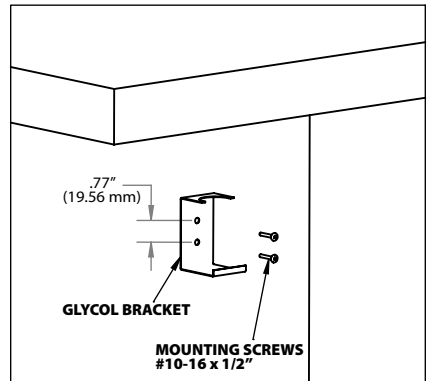

WIRE INSTALLATION

Reotemp recommends installing the wire through the door seal, probe access port, or cooler wall. On horizontal units, the preferred method is using the rear door seal as shown in **FIGURE 4**. On vertical units, remove the rear panel. There is typically a probe access hole. Probe and wires can be ran into that access hole. Alternatively, you can drill a hole just larger than the diameter of the wire (0.125" (3.175 mm)) through the wall. From inside the cooler/freezer, push the wire through the hole. Use mounting clips to secure the wire to the interior wall or shelving. Use silicone caulking to seal the hole around the wire.

FIGURE 3: GLYCOL SENSOR w/ BRACKET

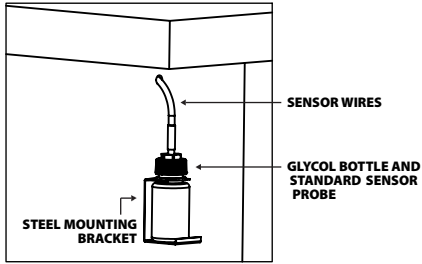
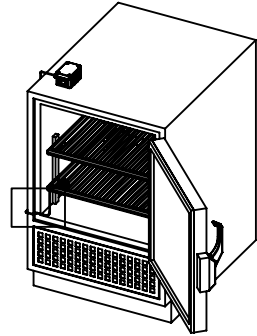

FIGURE 4: WIRE ROUTING



PRODUCT SPECIFICATIONS

2 oz ReoCube Thermal Isolation Bottle - Glycol	
Thermal Media:	Glycol
Bottle Material/Cap Material:	Nalgene (HDPE) / Polypropylene
Fluid Capacity:	67 ml (2 oz)
Cable Gland Material / Gland Material	Polyamide 6 / Neoprene
Cable Gland Torque Rating	1.66 Nm (14.7 lb. inch)
Probe Size Accepted:	0.098" to 0.256" (2.49mm to 6.50mm)
Operating Temperature Range:	-40 to 120°C (-40 to 248°F)
2 oz ReoCube Thermal Isolation Bottle - Glass Bead	
Thermal Media:	Glass Beads
Bottle Material/Cap Material:	Nalgene (HDPE) / Polypropylene
Fluid Capacity:	67 ml (2 oz)
Compression Fitting Material:	316 Stainless Steel
Probe Size Accepted:	0.1875" (4.762 mm)
Operating Temperature Range:	-100 to 120°C (-148 to 248°F)
8.5 oz ReoCube Thermal Isolation Bottle	
Thermal Media:	Glycol or Glass Beads
Bottle Material/Cap Material:	Nalgene (HDPE) / Polypropylene w/ PTFE Foam Liner
Fluid Capacity:	250 ml (8.5 oz)
Thermowell Material (3PT only):	316 SS Steel
Probe Size Accepted:	0.1875" (4.762 mm)
Operating Temp Range – Glycol:	-40 to 120°C (-40 to 248°F)
Operating Temp Range – Glass Bead:	-100 to 120°C (-148 to 248°F)
Bracket	
Bracket Material:	304 Stainless Steel
Mounting Screws / Material:	#10-16 Thread x 1/2" (12.7mm) / 410 Stainless steel
Thermal Isolation Media	
Glycol Properties / Glycol Freezing Point:	Food Grade USP (Propylene Glycol); Non-Toxic -59°C (-74.2°F)
Glass Bead Properties / Glass Freezing Point:	Soda Lime Glass / NA
General Specs	
Chemical Resistance:	Resistant to most acids, bases, and alcohols
Bottle Sterility:	Lab Quality, Non-Sterile
Storage Temperature Range:	-40 to 85°C (-40 to 185°F)
Operating Humidity Range:	10 to 100% RH, condensing
Agency Approvals:	RoHS2

