

GEARLESS DIRECT DRIVE GAUGE

Reotemp's PGL series pressure gauge is a gearless, direct drive design ideal for extreme applications where vibration and pulsation are prevalent. This gauge features a low volume sensing element, ideal for diaphragm seals.



PGL45A



PGL45E



PGL60E



PGL25H

FEATURES / BENEFITS

- Gearless, Helical Tube
- High Vibration/Pulsation Applications
- Solid Front Safety Design
- Low Volume Design for Low Displacement Diaphragm Seals

SPECIFICATIONS

Accuracy	±0.5% Grade 2A (6000+ = 0.5% upscale, 1% downscale)
Ambient Limits	ABS: -65°F/190°F GFN/Metal: -65°F/400°F
Process Limits	ABS: -65°F/250°F GFN/Metal: -65°F/600°F
Process Limits with Diaphragm Seals	-60°F/400°F (Direct Mount)* -110°F/750°F (Remote Mount or Cooling Tower) *Exact Limits depend on diaphragm seal and fill fluids.
Wetted Materials	Tube: Inconel X-750, Silver Brazed Socket: 316SS
Lens	Standard: Plastic (Acrylic) Optional: Tempered Safety Glass
Other Materials	Case: ABS, Stainless Steel, Aluminum, or GFN Dial: Stainless Steel Case-to-Socket: O-Ring
Fillable	No
Restrictor Screw	Yes, Removable
Maximum Working Pressure	Stable = 100% Momentary = 150% (up to 5,000psi)

GEARLESS DIRECT DRIVE GAUGE

HOW TO ORDER: Choose options to build a part number. For example: PGL45A1A2P18-P-HV

MODEL	DIAL SIZE	CASE	MATERIAL	MOUNT TYPE	CONNECTION	RANGE CODE	LENS
PGL = Gearless Direct Drive Gauge	45 = 4.5" Dial	A = ABS Turret Case (Std) B = ABS Case with Rear Flange C = ABS Case with No Flange E = ABS Case with Front Flange G = GFN (Glass-Filled Nylon) H = Aluminum Case M = Military Grade Aluminum S = Stainless Steel	1 = 316SS Socket Inconel X-750 Silver Brazed Tube	A = Bottom C = Back	2 = 1/2" NPT 4 = 1/4" NPT	P16 = 0-30 psi P17 = 0-60 psi P18 = 0-100 psi P19 = 0-160 psi P20 = 0-200 psi P21 = 0-300 psi	-P = Plastic (Acrylic) -T = Tempered Glass
	25 = 2.5" Dial	C = ABS Case with No Flange E = ABS Case with Front Flange H = Aluminum Case					
	60 = 6" Dial	E = ABS Case with Front Flange B = ABS Case with Rear Flange C = ABS Case with No Flange					

-HV

OPTIONS

- HV** = HiVis Dial
- EX** = Externally Adj. Dial
- C3** = 3pt Cal Cert
- MB** = Mirror Band Dial
- TS** = Stainless Steel Tag
- YC** = Case Color Yellow*
- RC** = Case Color Red*
- BC** = Case Color Blue*
- BK** = Case Color Black* (powder coat only, std on ABS)

GEARLESS DIRECT DRIVE GAUGE

PRESSURE GAUGES

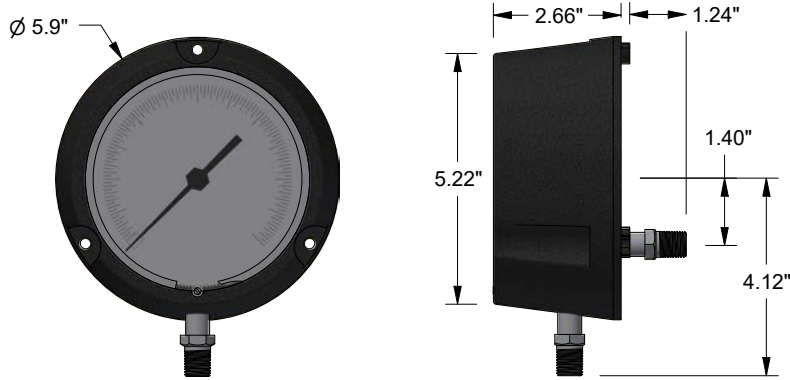

PGL45A CASE

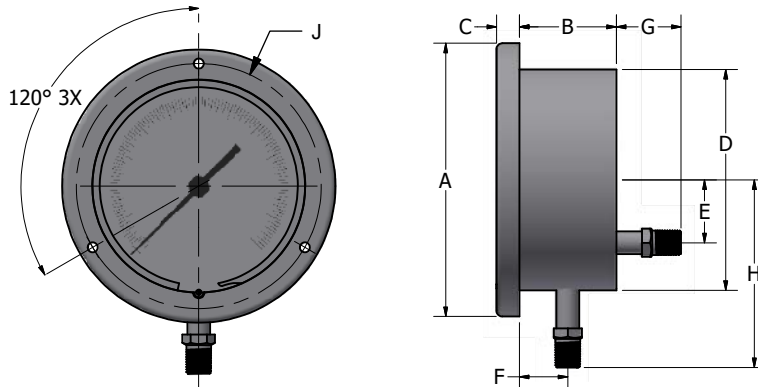

PGL E CASE

PGL E Case with Front Flange

Dial Size	"A"	"B"	"C"	"D"	"E"	"F"	"G"	"H"	"I"	"J"
2.5"	3.62"	2.03"	0.50"	2.75"	0.75"	1.50"	*	*	0.16"	3.13"
4.5"	6.00"	2.13"	0.50"	4.85"	1.38"	1.06"	*	*	0.22"	5.38"
6"	7.75"	2.13"	0.50"	6.31"	1.38"	1.06"	*	*	0.28"	7.00"

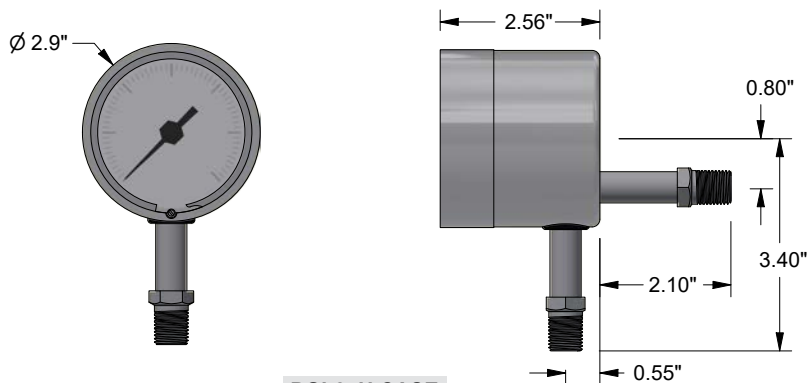

PGL25H CASE