

THIS DRAWING AND SPECIFICATIONS ARE THE PROPERTY OF REOTEMP INSTRUMENT CORP., AND ARE ISSUED IN STRICT CONFIDENCE AND SHALL NOT BE REPRODUCED, COPIED OR USED AS THE BASIS FOR MANUFACTURE OR SALE OF ITEMS DEPICTED HEREIN WITHOUT WRITTEN PERMISSION FROM REOTEMP INSTRUMENT CORP.

REVISIONS			
REV	DESCRIPTION	DATE	APPROVED
A	INITIAL RELEASE	6/5/24	SMH

NOTES (UNLESS OTHERWISE SPECIFIED)

- 1) DIMENSIONS ARE IN INCHES
- 2) BEST COMMERCIAL MANUFACTURING PRACTICES APPLY, UNLESS OTHERWISE SPECIFIED.

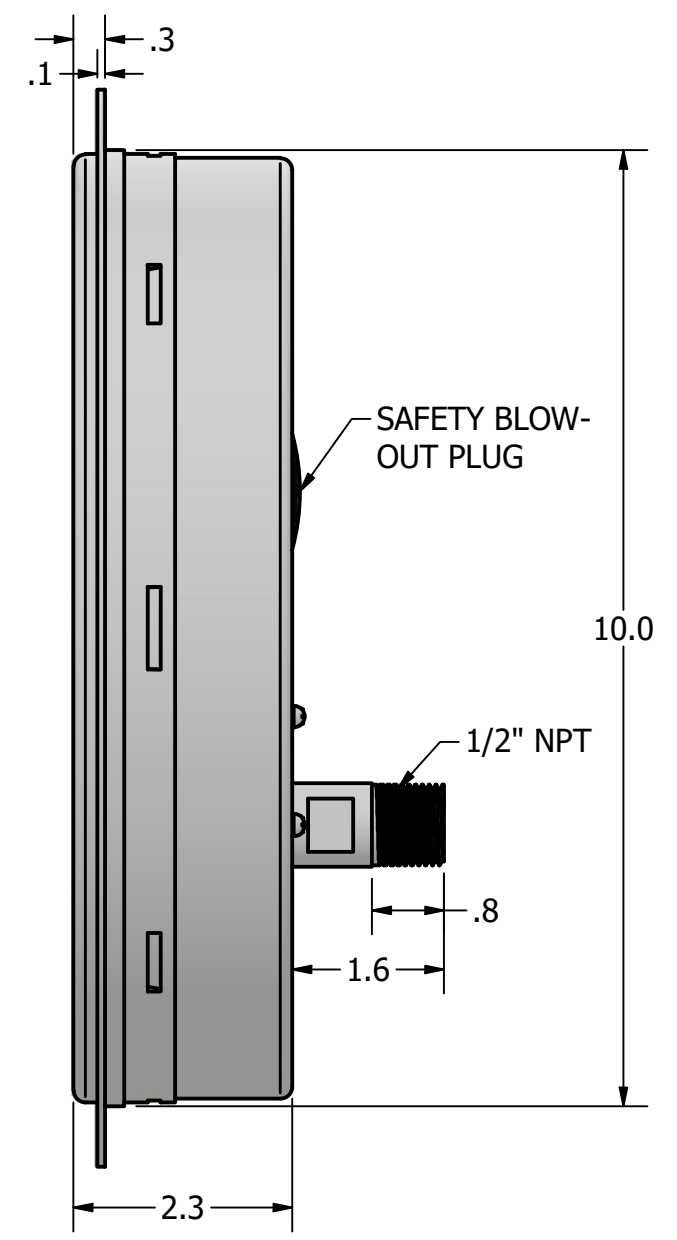
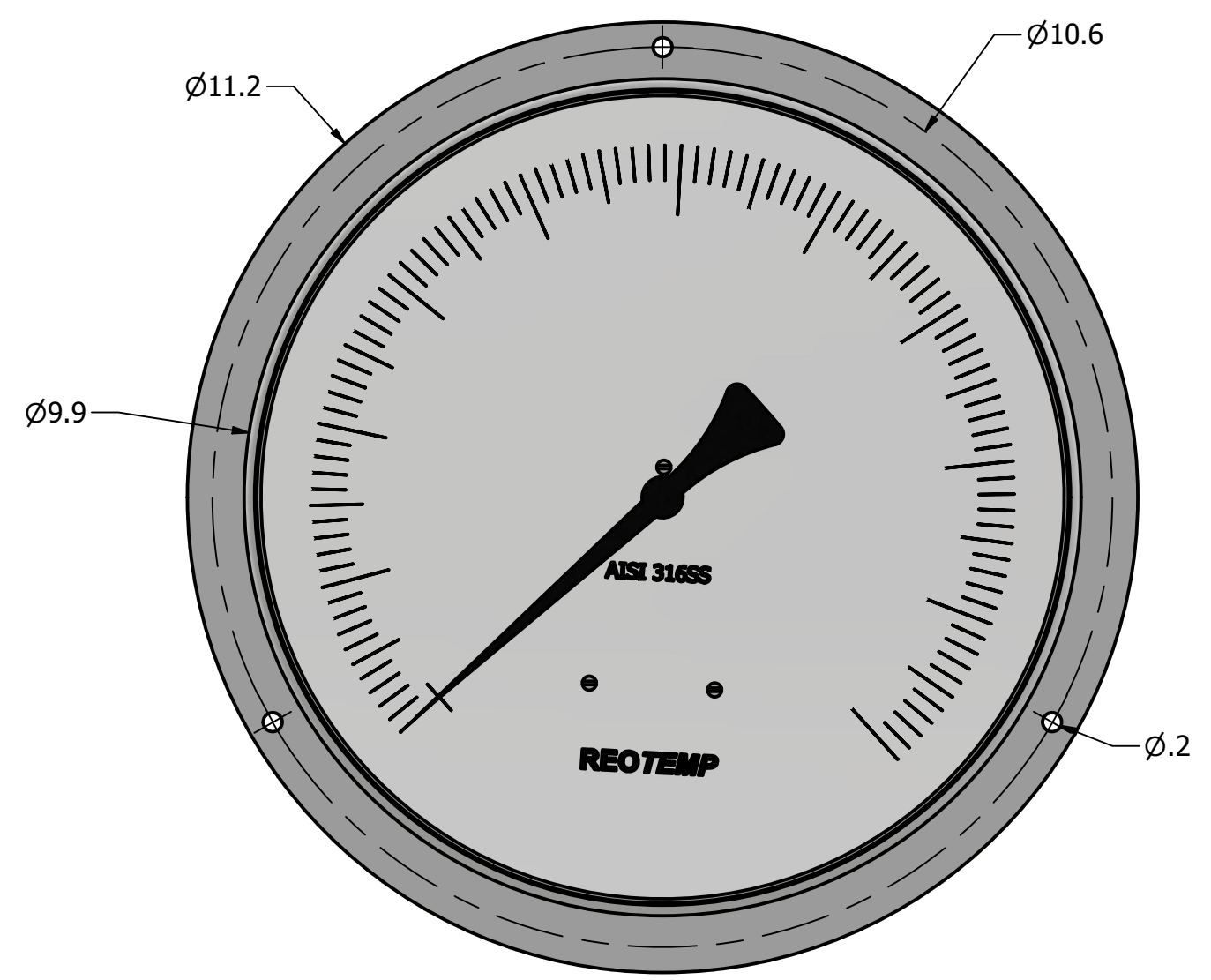
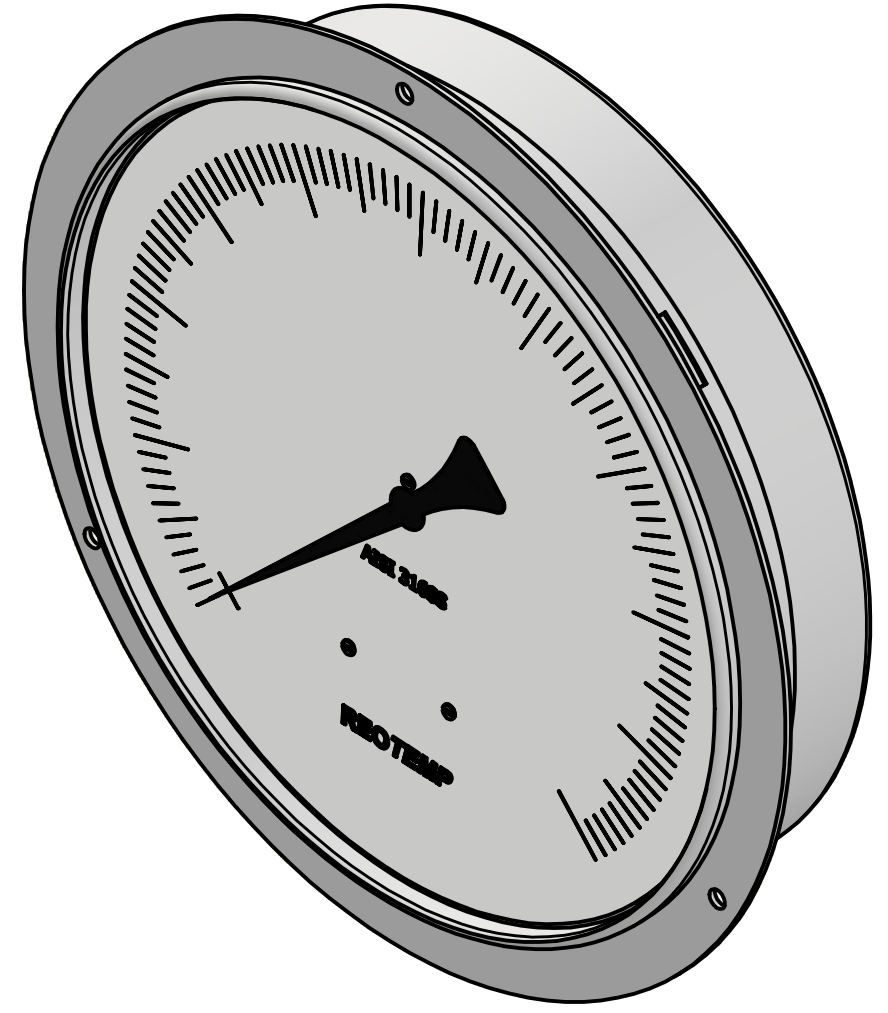

PART NAME PR10 1/2 NPT Back Connection and Front Flange															
<small>UNLESS OTHERWISE SPECIFIED DIMENSIONS ARE IN INCHES TOLERANCES ARE:</small> <table border="0"> <tr> <td>DECIMALS</td> <td>ANGLES</td> <td>SURFACES</td> </tr> <tr> <td>.X ± .03</td> <td>±1°</td> <td rowspan="4">63</td> </tr> <tr> <td>.XX ± .01</td> <td></td> </tr> <tr> <td>.XXX ± .005</td> <td>FRACTIONS</td> </tr> <tr> <td>.XXXX ± .002</td> <td>±1/32</td> </tr> </table>		DECIMALS	ANGLES	SURFACES	.X ± .03	±1°	63	.XX ± .01		.XXX ± .005	FRACTIONS	.XXXX ± .002	±1/32	Reotemp Instrument Corporation 10656 Roselle Street San Diego, CA 92121 USA REOTEMP Phone: (858) 784-0710 Fax: (858) 784-0720	
DECIMALS	ANGLES	SURFACES													
.X ± .03	±1°	63													
.XX ± .01															
.XXX ± .005	FRACTIONS														
.XXXX ± .002	±1/32														
DATE	6/5/24	DRAWN BY	MP												
APPROVED	SMH	REV	A												
PART NO	C	CAGE CODE	24793												
DWG NO															
SCALE	NTS	FILE NAME:													
FIRST USED ON		SHEET	1 OF 2												