

THIS DRAWING AND SPECIFICATIONS ARE THE PROPERTY OF REOTEMP INSTRUMENT CORP., AND ARE ISSUED IN STRICT CONFIDENCE AND SHALL NOT BE REPRODUCED, COPIED OR USED AS THE BASIS FOR MANUFACTURE OR SALE OF ITEMS DEPICTED HEREIN WITHOUT WRITTEN PERMISSION FROM REOTEMP INSTRUMENT CORP.

NOTES (UNLESS OTHERWISE SPECIFIED)

- 1) DIMENSIONS ARE IN INCHES
- 2) BEST COMMERCIAL MANUFACTURING PRACTICES APPLY, UNLESS OTHERWISE SPECIFIED.

REVISIONS			
REV	DESCRIPTION	DATE	APPROVED
A	INITIAL RELEASE	6/5/24	SMH

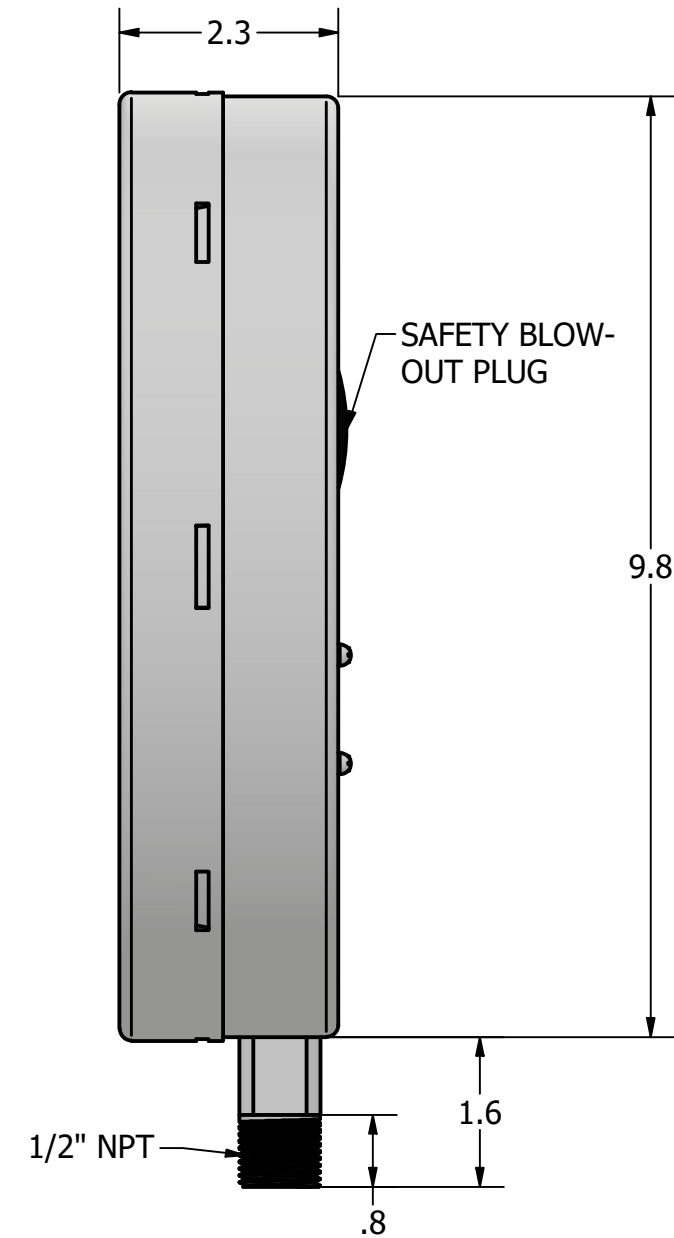
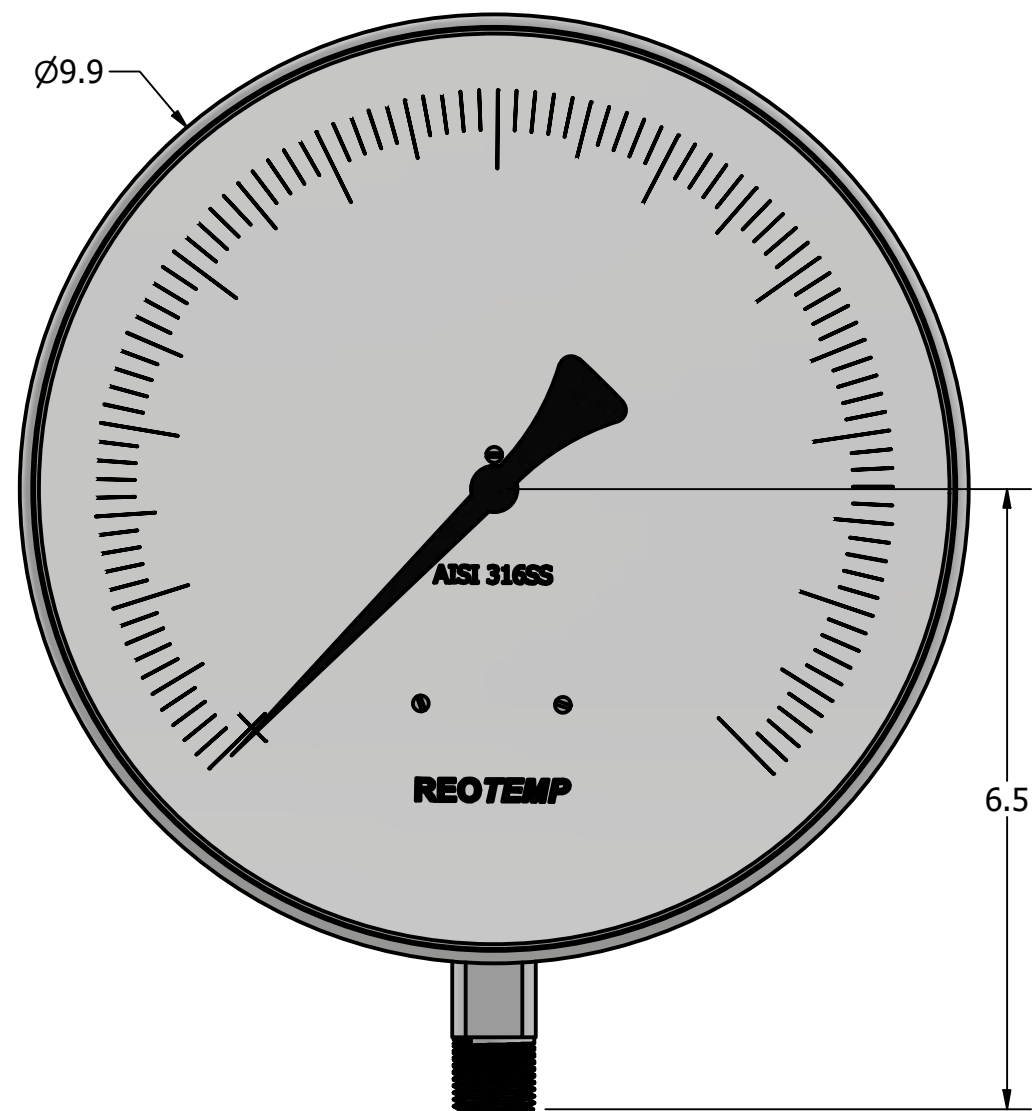
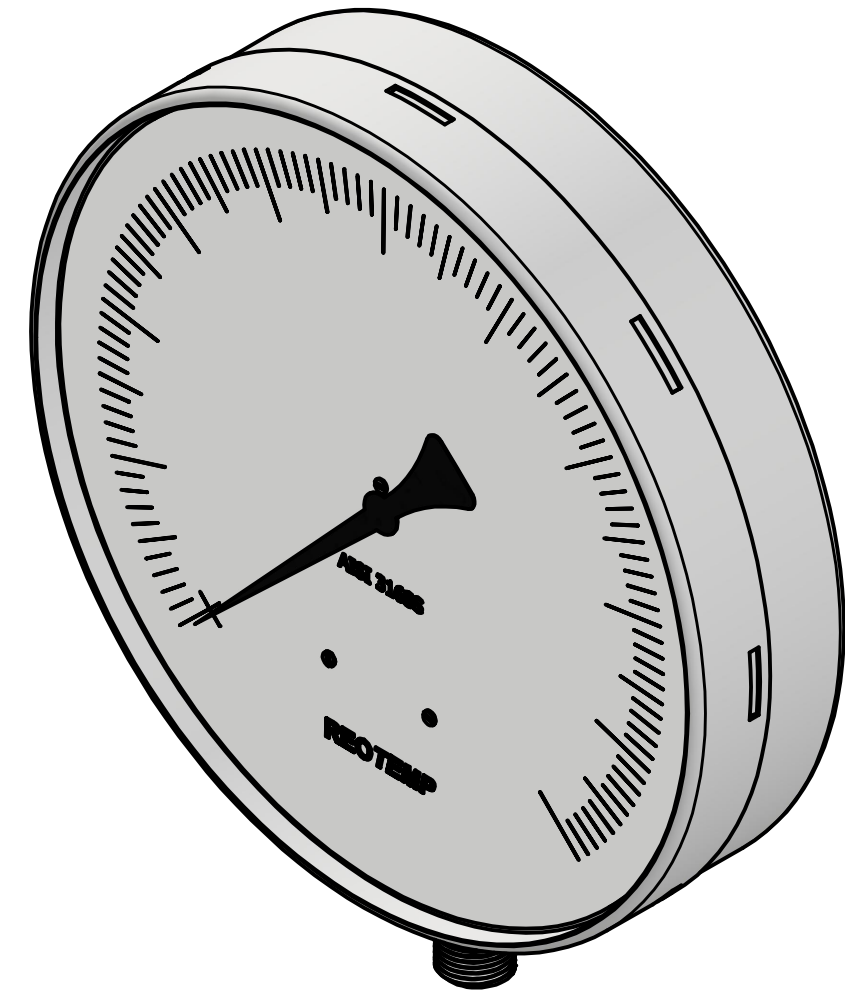

PART NAME PR10 1/2 NPT Bottom Connection			
UNLESS OTHERWISE SPECIFIED DIMENSIONS ARE IN INCHES TOLERANCES ARE:		Reotemp Instrument Corporation 10656 Roselle Street San Diego, CA 92121 USA Phone: (858) 784-0710 Fax: (858) 784-0720	
DECIMALS .X ± .03 .XX ± .01 .XXX ± .005 .XXXX ± .002 RADII = 1/32	ANGLES ±1° FRACTIONS ±1/32	SURFACES 63√	DATE 6/5/24 DRAWN BY MP APPROVED SMH
PART NO	SIZE C	CAGE CODE 24793	DWG NO REV A
FIRST USED ON	SCALE: NTS	FILE NAME:	SHEET 1 OF 2